



**InGaAs SWIR USB3 camera**

**Two-stage TEC cooling**

**High resolution up to 1.3MP**

**Visible and SWIR imaging 400nm-1700nm**

**High sensitivity low noise**

**High quantum efficiency**

V1300IR is a TE-Cooling USB3.0 InGaAs SWIR camera, which adopts Sony IMX990 1/2-Type Short-Wavelength Infrared (SWIR) Image Sensor. It is suitable to capture images in both visible range and SWIR range, covering 400nm to 1700nm. With smaller pixel size of  $5\mu\text{m}$ , imaging shows higher precision for quantitative researches.

## Spectral Response

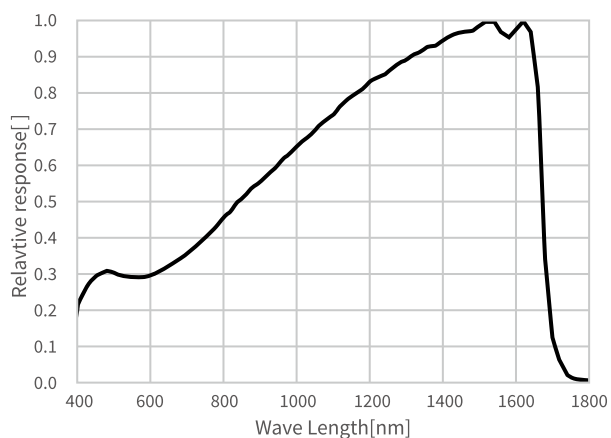

A Spectral Response Curve

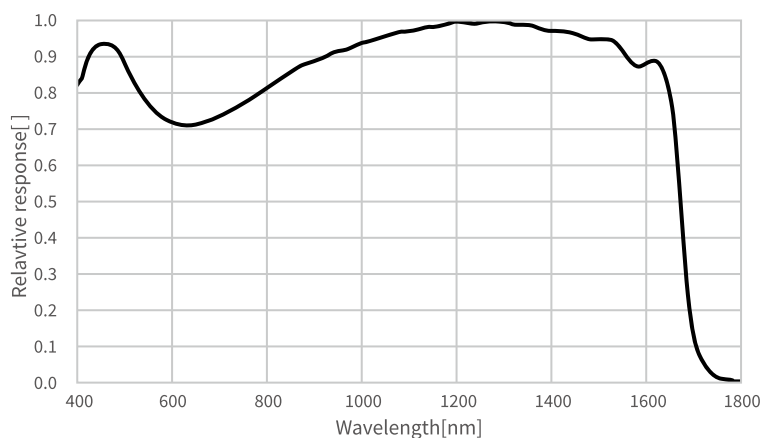

A Quantum Efficiency

# Specifications

## V1300IR

1.31M pixels 1/2" CMOS USB3.0 industrial camera

Sensor model	Sony IMX990-AABA-C
Pixel size	5.0 $\mu\text{m}$ x 5.0 $\mu\text{m}$
Sensor size	1/2"
Frame rate	134.7fps@1280 x 1024, 260.7fps@640 x 512
Dynamic range	57dB
Signal-to-Noise ratio	200e-
Quantum efficiency	>75%
Gain range	1x-15x
Exposure time	50 $\mu\text{s}$ -3600sec
Shutter	Global shutter
Binning	Software2x2, 3x3, 4x4
Data interface	USB3.0
Data Format	Mono8 / Mono12
Cooling performance	25-30°C below ambient temperature

### General Specification

Power supply	DC12V Power adapter
Power consumption	<2.1W(no cooling) / <25W(cooling)
Temperature	Working temperature -20~60°C, storage temperature -40~85°C
Humidity	20%-80%, no condensation
Size	75mm×75mm×68mm
Weight	648g
Lens mount	C-mount
Software	ImageView/SDK
Operating system	Win32/WinRT/Linux/macOS/Android
Certification	CE, FCC

# Technical Drawing

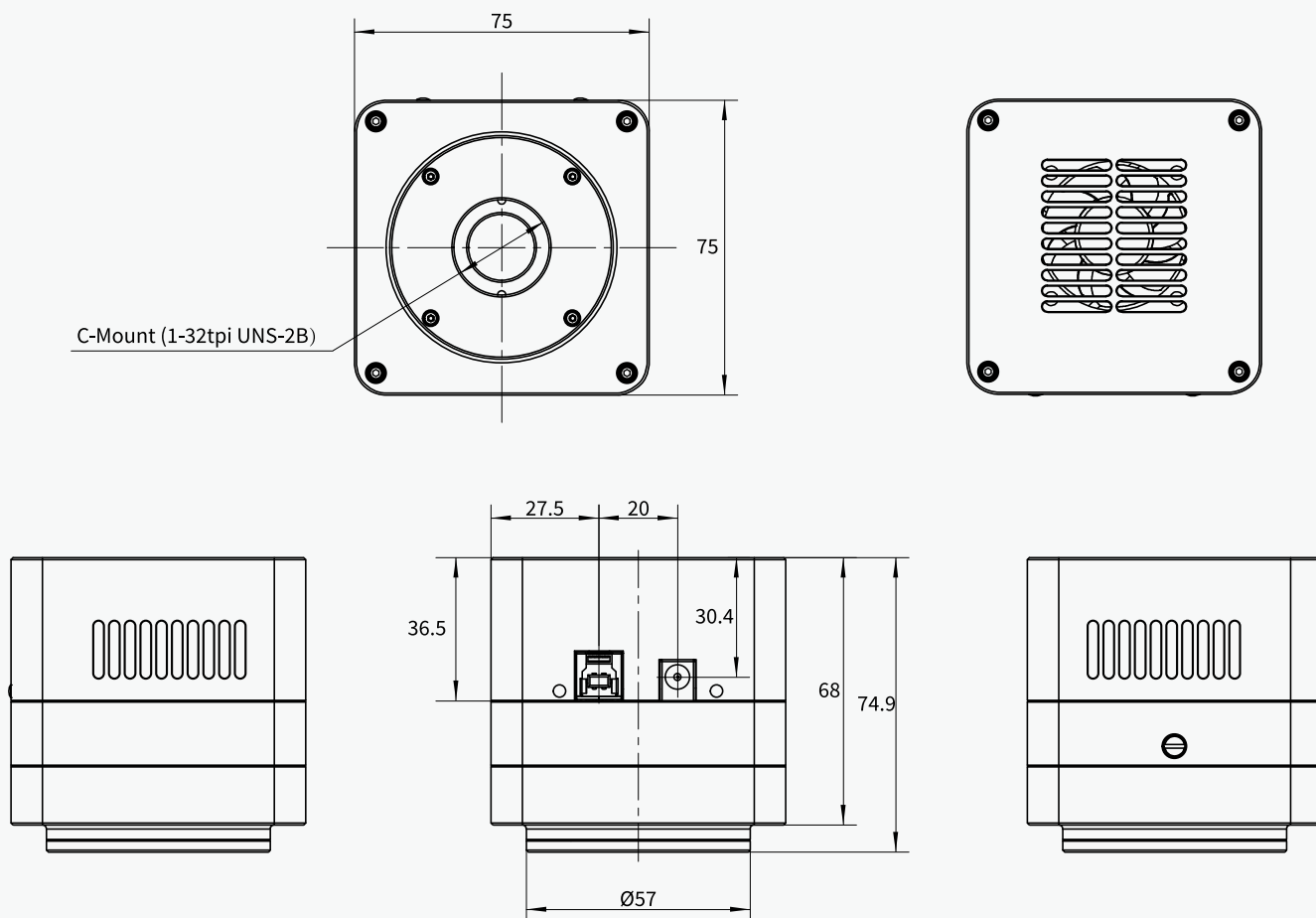

## Product application

Electronic board inspection, solar cell inspection, semiconduction inspection, transmission observation, produce inspection, identifying and sorting, water visualization, temperature observation, surveillance, anti-counterfeiting

Short wave infrared high-end night vision security applications are also the best choice.

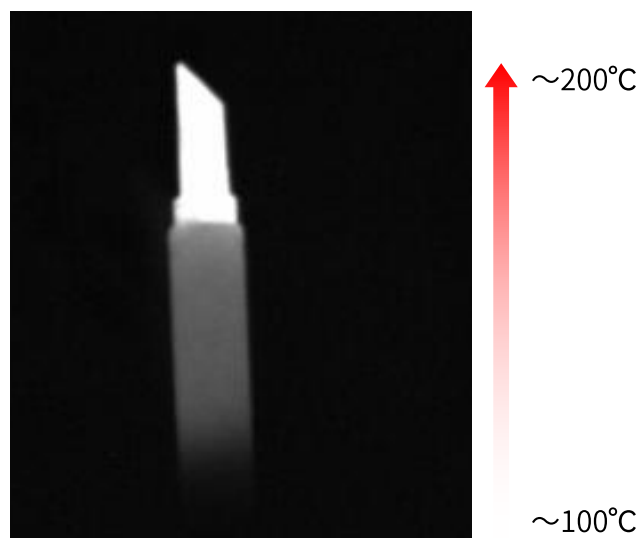

\*仕様、外觀は予告なく変更することがあります。



株式会社 Visualix <https://visualix.jp/>

〒650-0022 神戸市中央区元町通6-7-6 茶本ビル5・6F

info@visualix-jp.com